

穿壁联接器

WALL CONNECTOR

阀用安装配件
F A P





专业铸就品质 创新引领市场



上海焊思环保科技有限公司继美国戈尔公司 (W.L.Gore & Associates, Inc.) 卖掉上海袋配公司后，在2017年成立的一家专业环保公司，是一家拥有多年研制、生产和销售袋式除尘器过滤单元、自动清灰系统及配件的经验。

公司产品包括电磁脉冲阀、清灰控制仪、滤袋、滤袋框架、专用配件、电气控制柜及过滤筒等，是国内生产袋式除尘器配件品种最为齐全、质量最为优异的企业。公司的工厂测试设备齐全，生产工艺先进，所具有的模具设计加工、压铸、注塑、冲压、塑封、机械加工、焊接、装配等自动化及半自动化产品全套生产线使产品性能和质量均与国际同类产品接轨，并广泛应用于钢铁冶金、有色冶炼、建筑水泥、化工、

工业电站锅炉以及城市垃圾焚烧等行业中的粉尘治理和烟气净化，产品批量出口美国、欧洲、日本及东南亚等地区，在国内外市场享有很高的声誉和知名度。

公司的产品有 ISO 9001 质量管理体系认证，先后在中国环境保护产业里享有名气。

在技术领先产品适销对路的情况下，公司销售额及用户数量保持连年增长。公司将秉承和发展“以人为本”的原则，注重专业人才的引进、培养，以稳定提升产品质量及新品开发，扩大销售规模，为全球可持续性发展提供坚实的基础。

Introduction

Established in September 2017 after Gore sold out Shanghai Bag Filtration Equipment Co., Ltd, Shanghai AASF Technology Co., Ltd. is a famous company with a tradition of more than 30 years in developing, manufacturing and selling bag filtration component, automatic dust-clean system and accessories .

With a product line covers pulse jet valve, dust control device, filter bag, filter bag cage, special parts, electric control cabinet and filter cartridge, the company enjoys the most complete options and highest quality of its bag filtration components in China. The company's factory production facility covers an area of 500 m² and owns production lines with annual capacity of 200,000 pulse jet valves and 150,000 filter bags, and a production line with an annual capacity of 10000 dust control devices. With full range of testing equipments and advanced production techniques, the performance and quality of the company's automated and semi-automated production lines in mold design and processing, die casting, plastic injecting, press molding, plastic encapsulation, mechanical processing, welding and assembling have met the international standards for relevant categories. The company's products are widely used in dust treatment and smoke purification in ferrous metallurgy, non-ferrous metal metallurgy, construction cement, chemical, industrial power station boiler, urban trash burning and other applications. Its products are exported

in large quantities to US, Europe, and Southeast Asia and enjoy great reputation and awareness both at home and abroad markets.

Being awarded the titles of the Hi-tech Company in Shanghai", the company 's products have been qualified by the ISO9001 quality system certification and Quality inspection. The company has also been awarded the titles of "The Key Company in Environmental Protection in China", "A-class Company Creditable in Taxpaying in Shanghai", "A-class Company Creditable in Accounting in Shanghai" and was named "the AAA-class Company Adhering to Contract and Credit in Shanghai" . The company's 6 categories of products have all been qualified by the State Administration of Environment Protection's product certification and review.

Backed by leading technology, the company' s products sell well in the market. The total sale and the number of users have kept increasing for years. Adhering to the principle of "people-oriented", the company will focus on introducing in and cultivating human resources, stably improving product quality, developing new product, enlarging the sales scale, and providing a sound foundation for the sustainable development.

概述及用途 Description and Usage	>	3
型号含义 Type Definition	>	4
技术指标 Technical Index	>	4
产品结构 Product Structure	>	5
结构尺寸 Configuration Size	>	9
安装方法 Installation	>	15



概述及用途 Description and Usage

穿壁联接器由铝合金铸件、不锈钢冲件、橡胶件组成，用于密封容器内外管道的联接，如脉冲喷吹袋式除尘器的喷吹管与直角式电磁脉冲阀的联接（板壁式），淹没式电磁脉冲阀与输出管的联接（气包式），使用时不需焊接就能固定和可靠密封，便于安装和维修。

A wall connector consists of an aluminum alloy cast part, stainless punched part and rubber part and is for the connection of inner and outer pipe of airtight containers such as the connection between the blowing tube of pulse jet bag-house and rectangular pulse valve (batten wall mounted) and between submerged electromagnetic pulse valve and outlet pipe (head tank mounted). It can be reliably fixed and sealed without welding and is convenient for installation and maintenance.

特别提示 Special hint

穿壁联接器可以保持管道气体畅通，并解决管道外及容器的密封。但不能支撑其所联接的管道或容器等部件，用户应采取可靠的措施予以支撑。

A wall connector can keep the gas in the pipe flow freely and effectively seal the container connected to the pipe. But it should not be used to support the parts like the connected pipe and container. The user should take reliable actions to support them.



应用范围 Application range

型号 Models	应用范围 Application range
FAP-A-1	多孔板以下换袋的脉冲喷吹袋式除尘器与DMF-ZM系列电磁脉冲阀 Pulse jet bag-house with removable bag and DMF-ZM series electromagnetic pulse valve below perforated plate
FAP-A-2	多孔板以上换袋的脉冲喷吹袋式除尘器与DMF-Z/ZM系列电磁脉冲阀 Pulse jet bag-house with removable bag and DMF-Z/ZM series electromagnetic pulse valve above perforated plate
FAP-A-3	多孔板以上换袋的脉冲喷吹袋式除尘器与DMF-ZM系列电磁脉冲阀 Pulse jet bag-house with removable bag and DMF-ZM series electromagnetic pulse valve above perforated plate
FAP-B-1	方形气包与DMF-Y系列电磁脉冲阀（螺纹式联接） Square head and DMF-Y series electromagnetic pulse valve (thread connection)
FAP-B-2	方形气包与DMF-Y系列电磁脉冲阀（滑动式联接） Square head and DMF-Y series electromagnetic pulse valve (slip connection)
FAP-C-1	圆形气包与DMF-Z系列电磁脉冲阀输入端 Square head and the outlet end of DMF-Z series electromagnetic pulse valve



型号含义 Type Definition

F A P - X - X - X

阀用安装配件
Fittings for valve installation

A 板壁式 Batten wall mounted type
B 气包式 Head tank mounted type
C 气包式 Head tank mounted type

口径
Caliber

20 (G^{3/4}"), 25 (G1"),
40 (G1^{1/2}"), 50 (G2"),
62 (G2^{1/2}"), 76 (G3")

-1 单端 Single end
-2 双端 Dual end
-3 双端/接管 Pipe connected at dual ends

-1 罗纹式 Thread type
-2 滑动式 Slip type

-1 Z型输入端 Z valve's inlet end

技术指标 Index

工作压力 Operation pressure	≤ 0.6 Mpa	
工作介质 Operation medium	清洁空气 Clean air	
穿壁厚度 Wall crossing thickness	A 型板壁式 Model A batten wall mounted type	2~6mm
	B 型气包式 1"(25), 1 ^{1/2} "(40) Model B head tank mounted type	200mm
输出联结长度 Lead length for connection	2"(50)	250mm
	2 ^{1/2} "(62), 3"(76)	300mm
使用温度 Temperature for use	A 丁腈橡胶密封件 Butyronitrile rubber seal part	-10~110℃
	B 硅橡胶密封件 Butyronitrile rubber seal part	-35~220℃
使用环境 Environment for use	无腐蚀性气体的场合 Place free corrosive gas	

产品结构 Product Structure

1

FAP-A型板壁式穿壁连接器有单端、双端、双端带接管三种形式。分别由压紧螺母、碗形垫圈、锥形密封圈、扁螺母、密封片、穿壁管所组成。单端式为一端带有压紧螺母(见图1), 双端式两端都带有压紧螺母(见图2)。双端带接管是在双端的基础上增加了与电磁脉冲阀相联接的接管、调节螺母、垫圈、密封垫。接管与穿壁连接器一端的联接由两平面间垫密封片来密封(见图3)。

The FAP-A batten wall type wall connector is divided into three types-the single type, dual end type and dual end plus pipe type respectively consisting of compression nut, bowl washer, conical seal washer, jam nut, seal piece and wall-crossing pipe. The single end type has a compression nut at one end(see Figure 1). The dual end type has compression nuts at two ends (see Figure 2). The dual end plus pipe type is added with pipe connecting electromagnetic pulse valve, adjusting nut, washer and seal washer on the basis of the dual end type. The connection between the pipe and one end of the wall connector is sealed with a seal piece between the two planes (see Figure 3).

图1 FAP-A-1型单端式结构图

Fig.1. Structure of FAP-A-1 single end type



图2 FAP-A-2型双端式结构图

Fig.2. Structure of FAP-A-2 dual end type

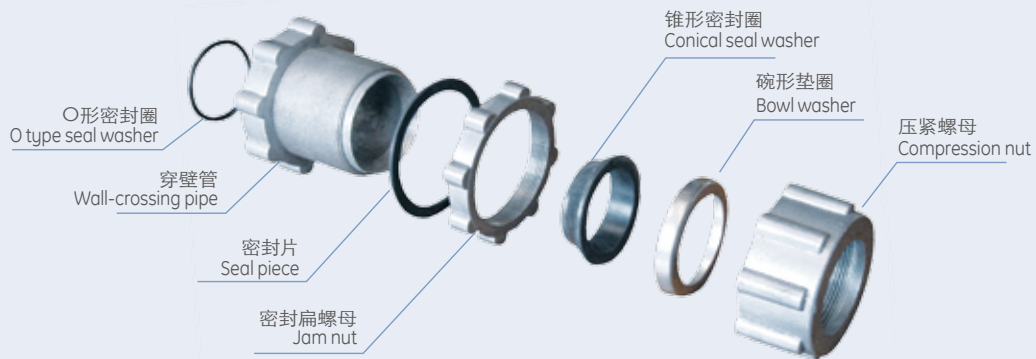

图3 FAP-A-3型双端带接管式结构图

Fig.3. Structure of FAP-A-3 dual end plus pipe

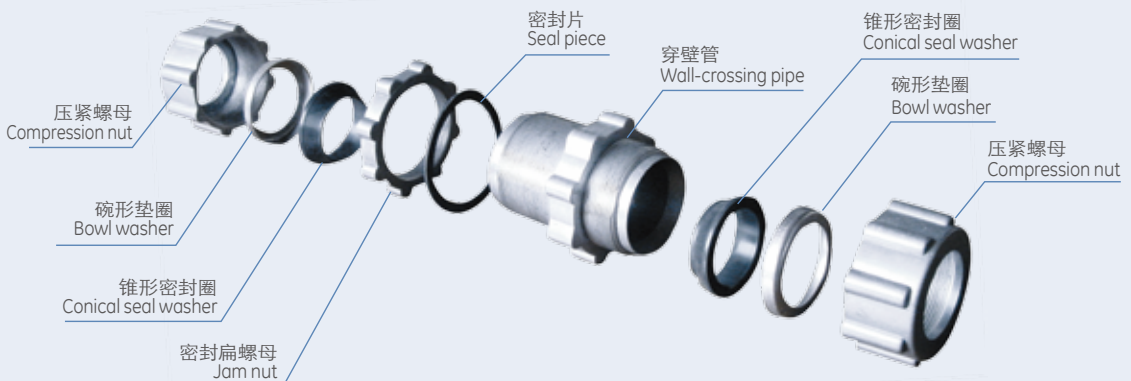
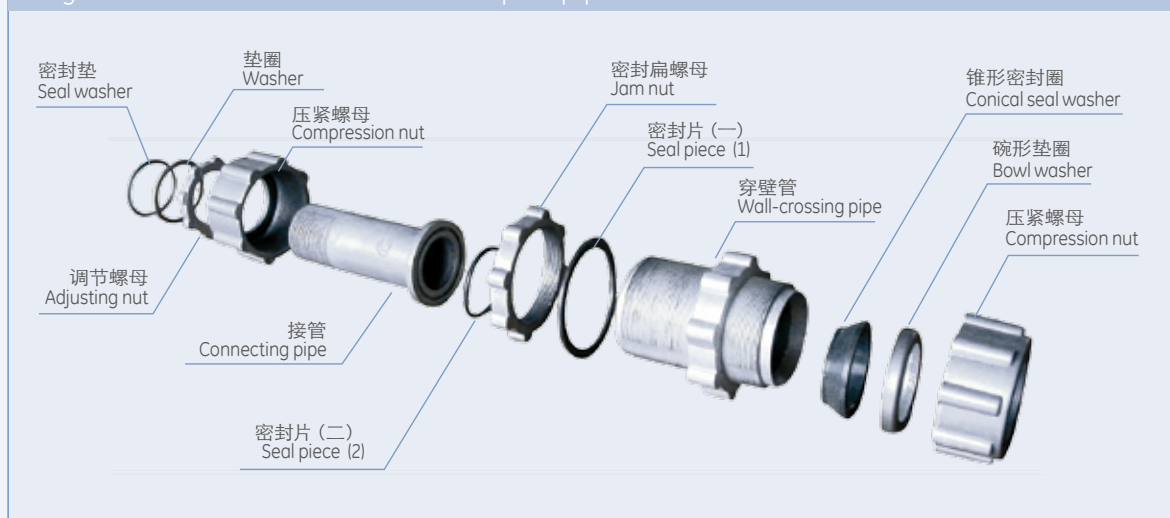

当穿壁管装入壁板安装孔时（孔径与穿壁连接器安装规格相对应、厚度为2~6mm壁板）。穿壁管的外凸缘面与板壁的一侧垫以密封片，并拧紧密封扁螺母来夹紧板壁和密封片，可使板壁内外两侧密封。穿壁管的内孔能穿过其相应规格的管道，管道的外壁上套有锥形密封圈，通过拧紧压紧螺母使锥形密封圈的內孔收缩而紧箍管道的外壁，使管道的外壁与外界密封。双端带接管中的接管是使电磁脉冲阀与穿壁管相联，并可调整电磁脉冲阀的安装位置。

When getting the wall-crossing pipe through the installation hole of the wall panel (with a thickness of 2~6mm and its diameter in compliance with the installation specifications of the wall connector), put a seal piece between the flange of the wall-crossing pipe and one side of the batten wall, tighten the jam nut to clamp the batten wall and the seal piece and seal from the outside and inside of the batten wall. A pipe with relative specifications may go through the inner hole of the wall-crossing pipe. A conical seal washer is slipped on the outer wall of the pipe. Tighten the compression nut to narrow the inner hole of the conical seal washer and make the outer wall of the pipe firmly clamped and sealed from the outside. The pipe of the dual end plus pipe type is used to connect the electromagnetic pulse valve and the wall-crossing pipe and adjust the electromagnetic pulse valve in its installation.

2

FAP-B-1型（螺纹式1"、1¹/₂"）气包式穿壁连接器由碗形垫圈、锥形密封圈、压紧螺母、密封片、穿壁管所组成（见图4）。

The FAP-B-1 (thread type 1", 1¹/₂") head tank mounted type wall connector consists of bowl washer, conical seal washer, compression nut, seal piece and wall-crossing pipe (see Figure 4).

图4 FAP-B-1型螺纹式结构图

Fig.4. Structure of FAP-B-1 thread type

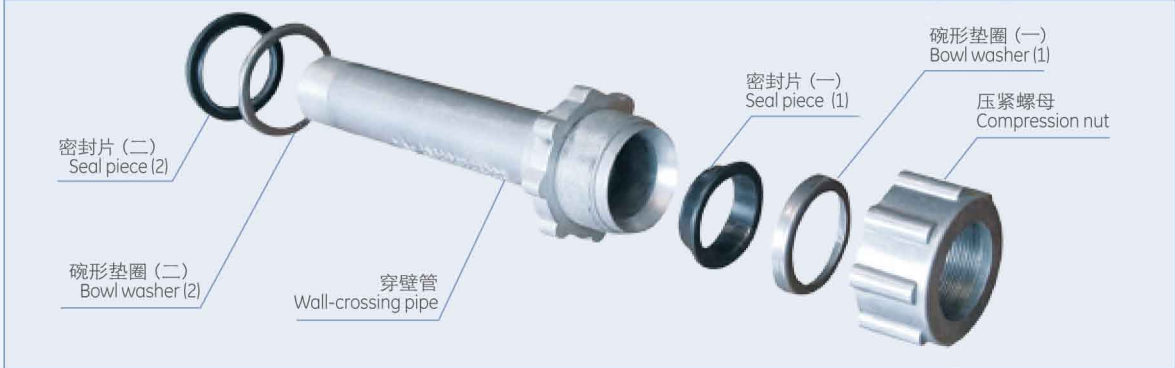

当穿壁管装入气包安装孔时(孔径与穿壁连接器安装规格对应,穿壁管长度与气包相配),穿壁管的一端外凸缘面与气包的外侧平面垫以密封片及碗形垫圈,另一端罗纹与阀体罗纹口拧紧,使气包内外密封。穿壁管的输出端内孔能穿过其相应规格的管道,管道的外壁上套有锥形密封圈,通过拧紧压紧螺母使锥形密封圈的內孔收缩而紧箍管道的外壁,使管道的外壁与外界密封。

When getting the wall-crossing pipe through the installation hole of head (with the hole diameter in compliance with the installation specifications of the wall connector and the length of the wall-crossing pipe matching the head), put a seal piece and a bowl seal washer between the flange of one end of the wall-crossing pipe and on outer plane of the head. The other thread end should be tightened onto the thread hole of the valve to seal from the outside and inside of the batten wall. A pipe with relative specifications may go through the inner hole of the outlet end of the wall-crossing pipe. A conical seal washer is slipped on the outer wall of the pipe. Tighten the compression nut to narrow the inner hole of the conical seal washer and make the outer wall of the pipe firmly clamped and sealed from the outside.

FAP-B-2型(滑动式2"、2¹/₂"、3")气包式穿壁连接器由密封圈、接头螺母、碗形垫圈、外密封片、内密封片、穿壁管所组成(见图5)。

The FAP-B-2 (slip type 2", 2¹/₂", 3") head tank mounted type wall connector consists of seal washer, collar nut, bowl washer, outer seal piece, inner seal piece and wall-crossing pipe (see Figure 5).

图5 FAP-B-2型滑动式结构图

Fig.5. Structure of FAP-B-2 the slip type



穿壁管装入气包安装孔时（孔径与穿壁连接器安装规格对应，穿壁管长度与气包相配），穿壁管的一端法兰面与气包的内侧平面垫以密封片，另在气包的外侧平面也垫有密封片及碗形垫圈，旋上接头螺母并拧紧，使气包的内外密封。在接头螺母的内孔装有密封圈，可直接插入相应规格的管道，穿壁管的另一端插入阀体内的密封圈。

When getting the wall-crossing pipe through the installation hole of head (with the hole diameter in compliance with the installation specifications of the wall connector and the length of the wall-crossing pipe matching the head), put a seal piece between the flange of one end of the wall-crossing pipe and one inner plane of the head and a seal piece and bowl washer on the outer plane of the head. Tighten the collar nut to seal the head from its outside and inside. A pipe with relative specifications may go directly through the inner hole of the collar nut with a seal washer. The other end of the wall-crossing pipe goes through the seal washer inside the valve.

3

FAP-C-1型连接器由接头、密封片、压紧螺母、接管、调节螺母、垫圈、密封垫所组成（见图6）。

The FAP-C-1 connector consists of the joint, seal piece, compression nut, connecting pipe, adjusting nut, washer, seal piece (see Figure 6).

图6 FAP-C-1型结构图

Fig.6. Structure of FAP-C-1

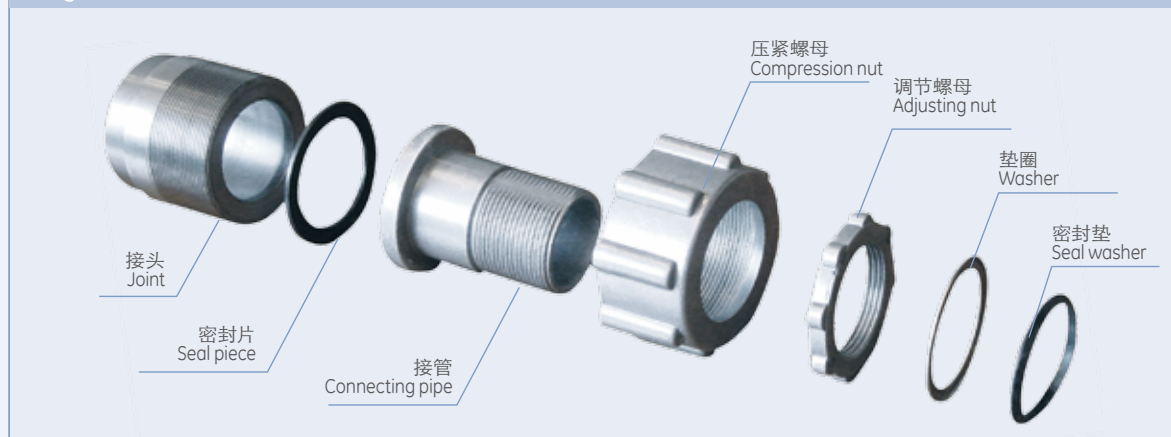

接头可直接焊于安装电磁脉冲阀的气包上，接管一端的螺纹与电磁脉冲阀螺纹相联接，并可调整电磁脉冲阀的安装位置。上述两者另一端的平面间垫有密封片并通过压紧螺母来联接并密封。

The jointed may directly welded onto the head of the electromagnetic pulse valve. One end of the connecting pipe is connected to the electromagnetic pulse valve through threads. The electromagnetic pulse valve may be adjusted in installation. Put a seal piece between the planes on other ends of the pipe and the valve and tighten the compression nut to connect and seal them.

结构尺寸 Configuration Size

图7 Fig.7. FAP-A-1-20

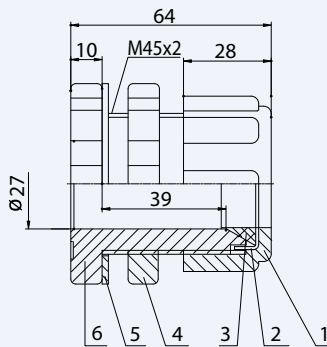

1. 压紧螺母
Compression nut
2. 碗形垫圈
Bowl washer
3. 锥形密封圈
Conical seal washer
4. 密封扁螺母
Jam nut
5. 密封片
Seal piece
6. 穿壁管
Wall-crossing pipe

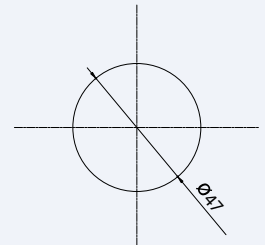
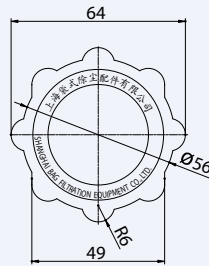

安装孔尺寸
Hole size for assembly

图8 Fig.8. FAP-A-1-25

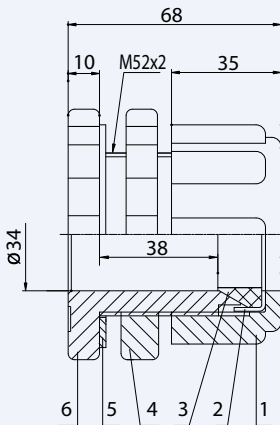

1. 压紧螺母
Compression nut
2. 碗形垫圈
Bowl washer
3. 锥形密封圈
Conical seal washer
4. 密封扁螺母
Jam nut
5. 密封片
Seal piece
6. 穿壁管
Wall-crossing pipe

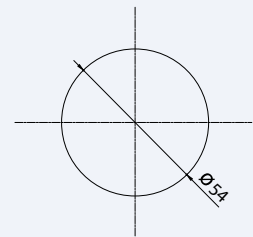
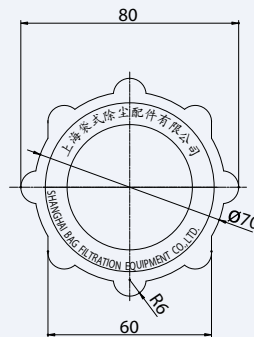

安装孔尺寸
Hole size for assembly

图9 Fig.9. FAP-A-1-40

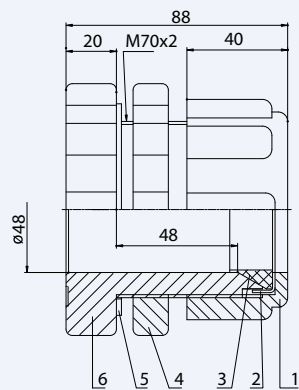

1. 压紧螺母
Compression nut
2. 碗形垫圈
Bowl washer
3. 锥形密封圈
Conical seal washer
4. 密封扁螺母
Jam nut
5. 密封片
Seal piece
6. 穿壁管
Wall-crossing pipe



图10 Fig.10. FAP-A-2-20



1. 压紧螺母
Compression nut
2. 碗形垫圈
Bowl washer
3. 锥形密封圈
Conical seal washer
4. 密封扁螺母
Jam nut
5. 密封片
Seal piece
6. 穿壁管
Wall-crossing pipe

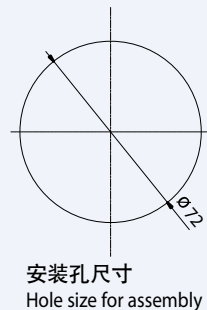
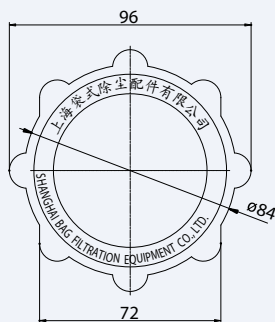
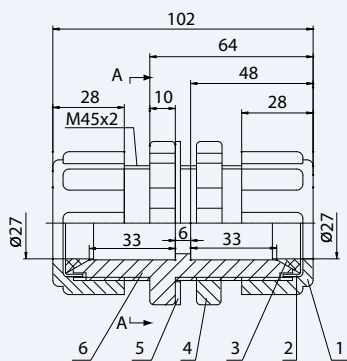

图11 Fig.11. FAP-A-2-25



1. 压紧螺母
Compression nut
2. 碗形垫圈
Bowl washer
3. 锥形密封圈
Conical seal washer
4. 密封扁螺母
Jam nut
5. 密封片
Seal piece
6. 穿壁管
Wall-crossing pipe

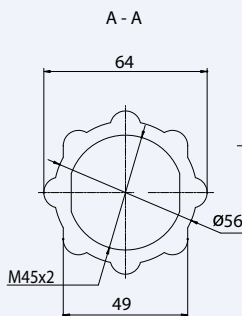
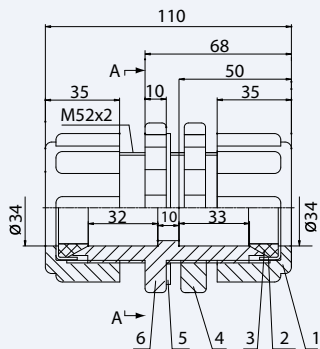

图12 Fig.12. FAP-A-2-40



图13 Fig.13. FAP-A-3-20

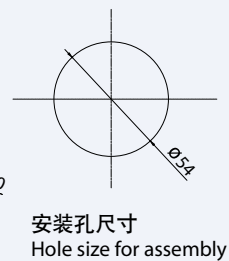
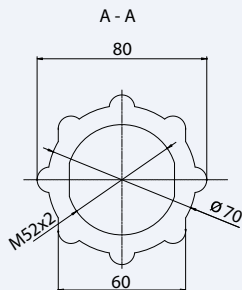

图14 Fig.14. FAP-A-3-25

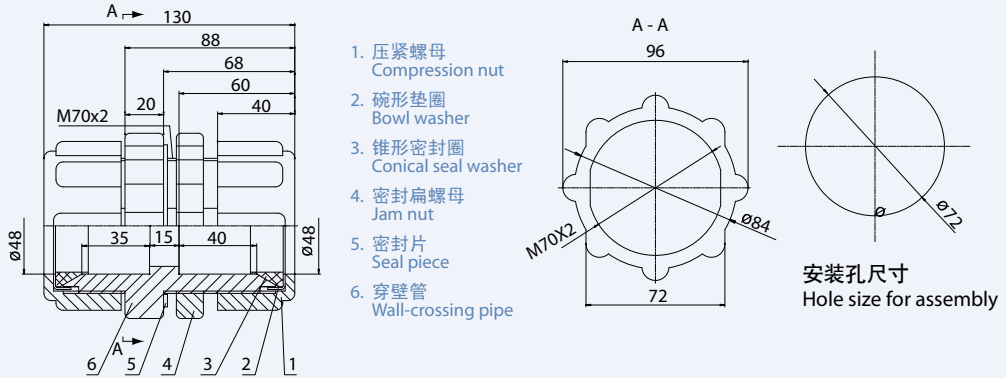

图15 Fig.15. FAP-A-3-40

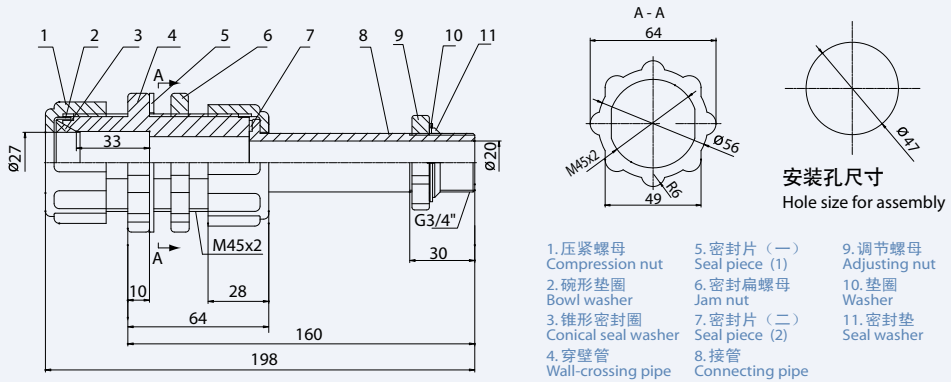

图16 Fig.16. FAP-B-1-25

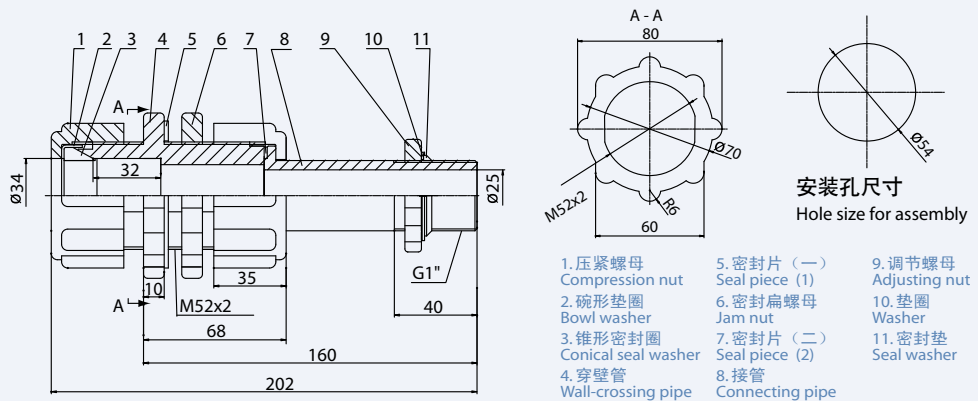

图17 Fig.17. FAP-B-1-40

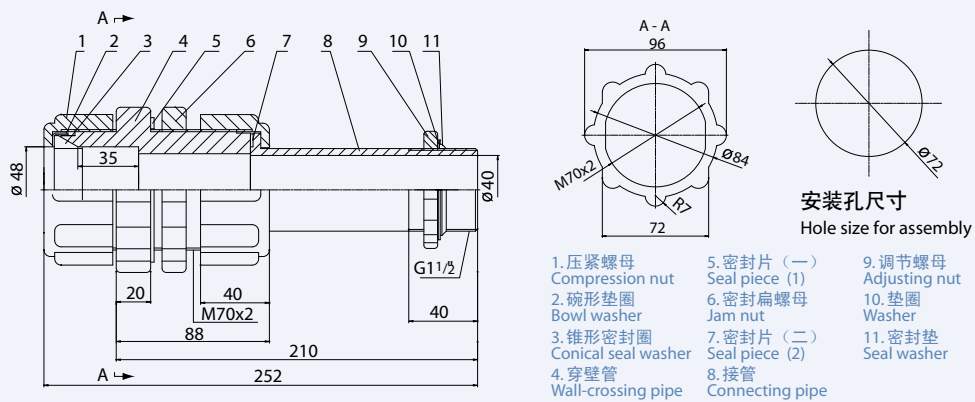

图18 Fig.18. FAP-B-2-50

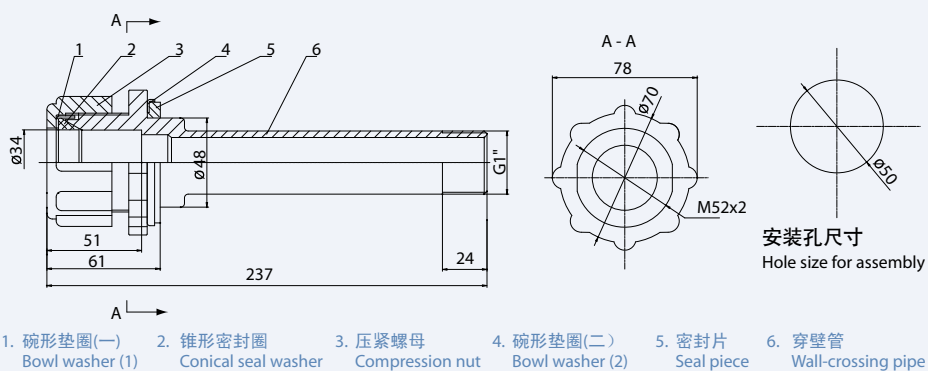

图19 Fig.19. FAP-B-2-62

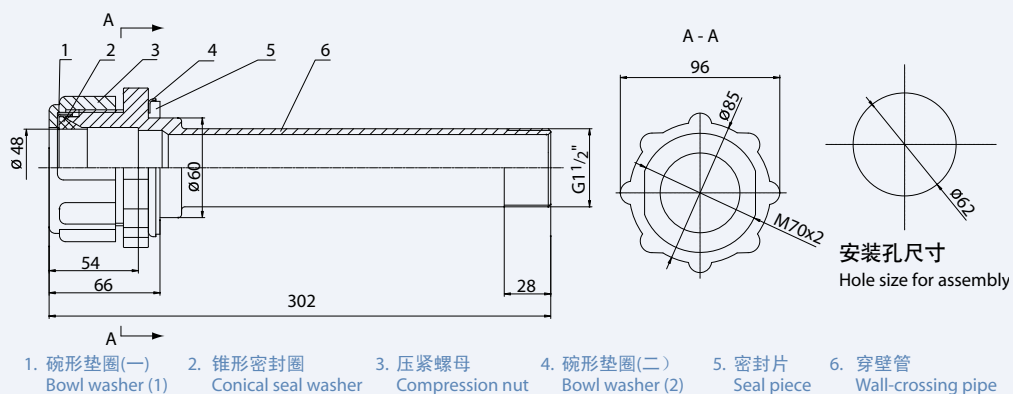

图20 Fig.20. FAP-B-2-76

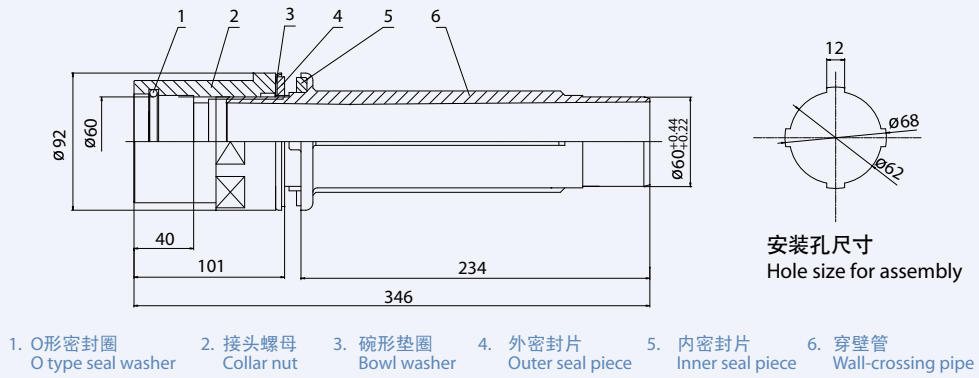

图21 Fig.21. FAP-C-1-20

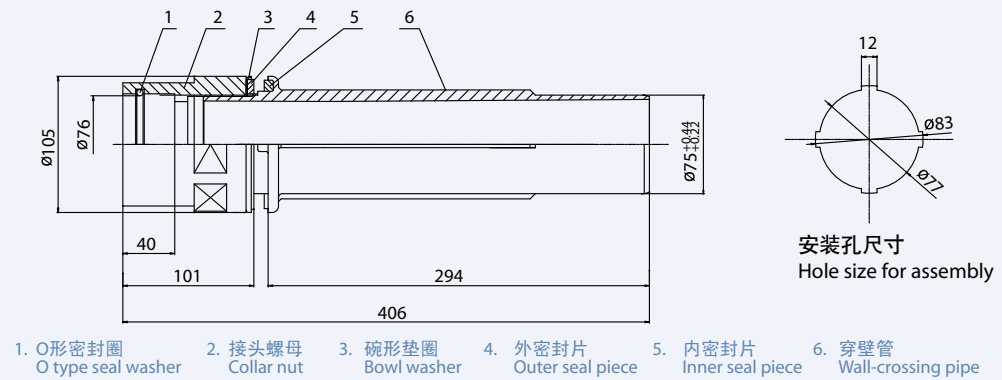

1. 接头
Joint
2. 密封片
Seal piece
3. 压紧螺母
Compression nut
4. 接管
Connecting pipe
5. 调节螺母
Adjusting nut
6. 垫圈
Washer
7. 密封垫
Seal washer

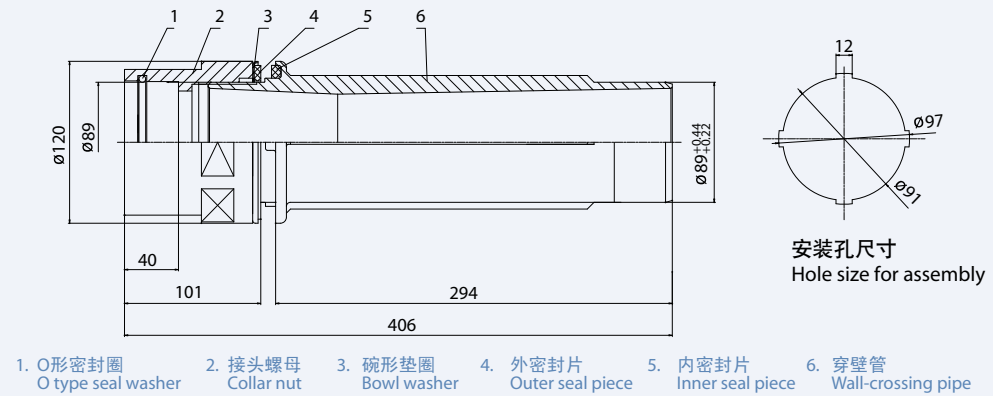
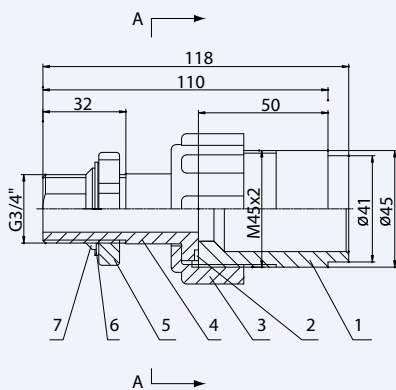

图22 Fig.22. FAP-C-1-25



1. 接头
Joint
2. 密封片
Seal piece
3. 压紧螺母
Compression nut
4. 接管
Connecting pipe
5. 调节螺母
Adjusting nut
6. 垫圈
Washer
7. 密封垫
Seal washer

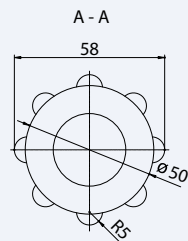
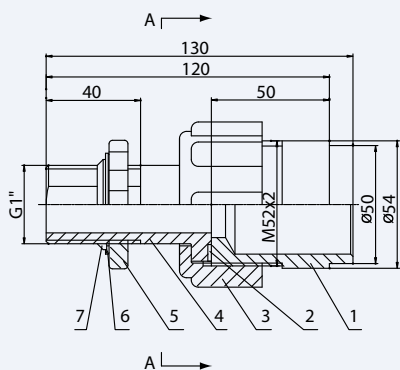

图23 Fig.23. FAP-C-1-40



1. 接头
Joint
2. 密封片
Seal piece
3. 压紧螺母
Compression nut
4. 接管
Connecting pipe
5. 调节螺母
Adjusting nut
6. 垫圈
Washer
7. 密封垫
Seal washer

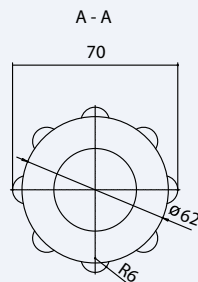
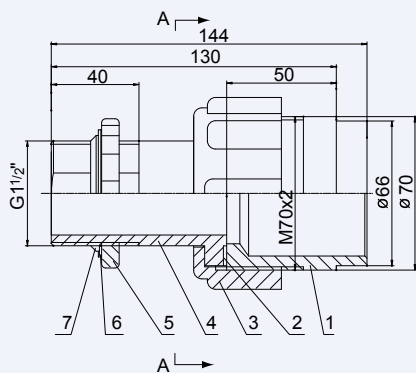
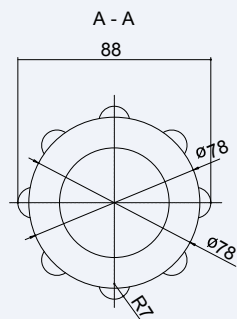

安装方法 Installation

各种型号的板壁式连接器安装方法见图24~29所示,供用户参考并可根据实际使用情况作适当变动,用户在安装各种连接器时请注意以下几点:

See Figures 24~29 for installation of various models of wall connectors, which are for user's reference and are subject to change as per the actual application. When installing them, users should pay attention to the following points:

- | | |
|---|---|
| 1 | <p>在安装的板壁或气包上的开孔尺寸大小要合适,偏小了不便安装并易损坏螺纹,过大了会影响密封和定位。</p> <p>The sizes of the hole in the batten wall or the head tank should be proper. Too small sizes are not convenient for installation and may result in the threads' damage. Too large sizes will affect the seal and location.</p> |
| 2 | <p>各种零件的安装位置要正确,特别是密封件的安装位置更为重要,否则将影响密封性能。</p> <p>Locate the parts properly in their installation, especially the seal piece. Otherwise, the airtight property will be affected.</p> |
| 3 | <p>在需要密封的罗纹处,产品出厂时已在罗纹处涂上密封膏,适当拧紧即可密封(密封膏可多次拆装仍有效)。</p> <p>The producer has applied the seal cream (it is effective after several times of dismantling and installing) on the threads that need to be sealed when the product is delivered. Properly tighten the parts may ensure the seal.</p> |
| 4 | <p>在安装滑动式气包穿壁连接器时,穿壁管在插入阀体密封圈前请适当涂上润滑剂,以方便安装。</p> <p>When installing the slip head wall connector, properly apply the lubricant before putting the wall-crossing pipe through the valve's seal washer for convenient installation.</p> |
| 5 | <p>穿壁管和螺母在旋进时,螺纹间应无杂质,必要时可涂上润滑剂,并不可过份拧紧以造成螺纹的损坏。</p> <p>There should not be any substance between threads. Apply the lubricant if necessary. Tighten the crossing pipe and nut properly to avoid any damage to threads.</p> |

图24 FAP-A-1型安装图

Fig.24. Installation of FAP-A-1



图25 FAP-A-2型安装图

Fig.25. Installation of FAP-A-2

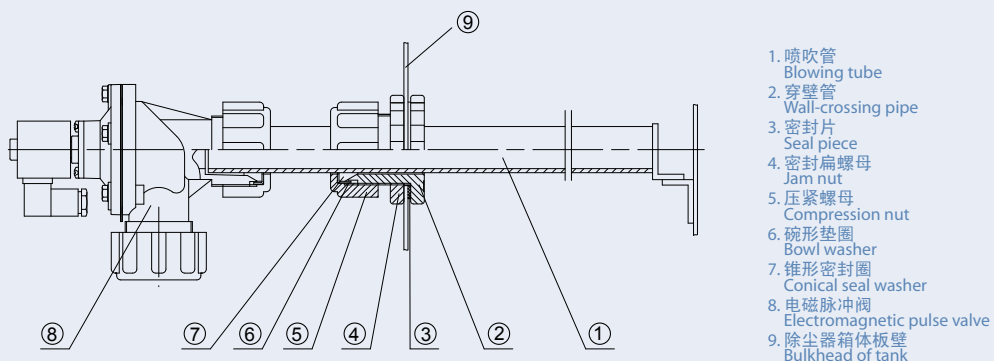
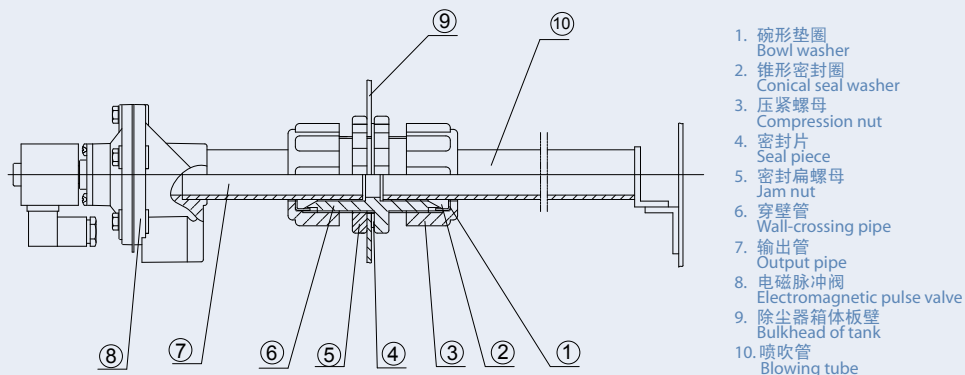

- 1. 碗形垫圈
Bowl washer
- 2. 锥形密封圈
Conical seal washer
- 3. 压紧螺母
Compression nut
- 4. 密封片
Seal piece
- 5. 密封扁螺母
Jam nut
- 6. 穿壁管
Wall-crossing pipe
- 7. 输出管
Output pipe
- 8. 电磁脉冲阀
Electromagnetic pulse valve
- 9. 除尘器箱体板壁
Bulkhead of tank
- 10. 喷吹管
Blowing tube

图26 FAP-A-3型安装图

Fig.26. Installation of FAP-A-3

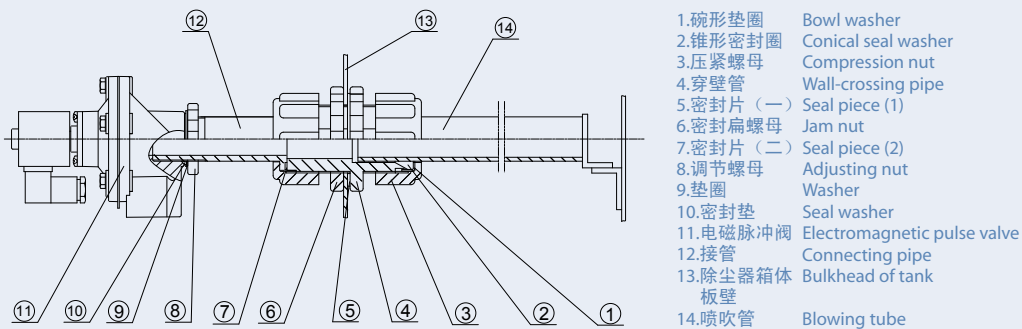

- 1. 碗形垫圈
Bowl washer
- 2. 锥形密封圈
Conical seal washer
- 3. 压紧螺母
Compression nut
- 4. 穿壁管
Wall-crossing pipe
- 5. 密封片 (一)
Seal piece (1)
- 6. 密封扁螺母
Jam nut
- 7. 密封片 (二)
Seal piece (2)
- 8. 调节螺母
Adjusting nut
- 9. 垫圈
Washer
- 10. 密封垫
Seal washer
- 11. 电磁脉冲阀
Electromagnetic pulse valve
- 12. 接管
Connecting pipe
- 13. 除尘器箱体板壁
Bulkhead of tank
- 14. 喷吹管
Blowing tube

图27 FAP-B-1型安装图

Fig.27. Installation of FAP-B-1

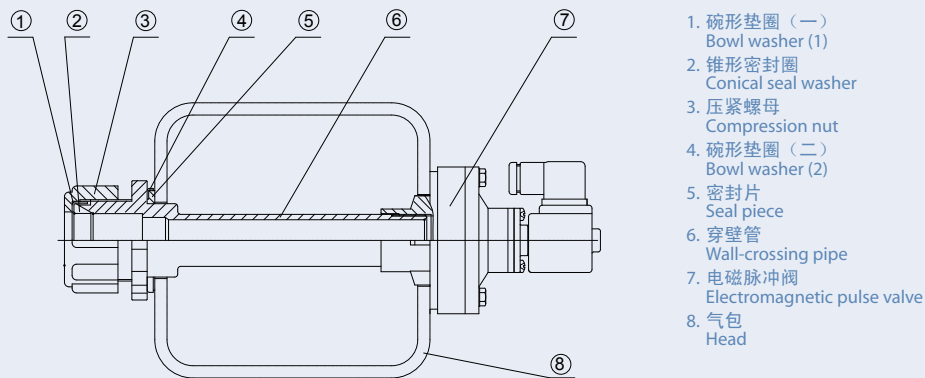

- 1. 碗形垫圈 (一)
Bowl washer (1)
- 2. 锥形密封圈
Conical seal washer
- 3. 压紧螺母
Compression nut
- 4. 碗形垫圈 (二)
Bowl washer (2)
- 5. 密封片
Seal piece
- 6. 穿壁管
Wall-crossing pipe
- 7. 电磁脉冲阀
Electromagnetic pulse valve
- 8. 气包
Head

图28 FAP-B-2型安装图

Fig.28. Installation of FAP-B-2



图29 FAP-C-1型安装图

Fig.29. Installation of FAP-C-1



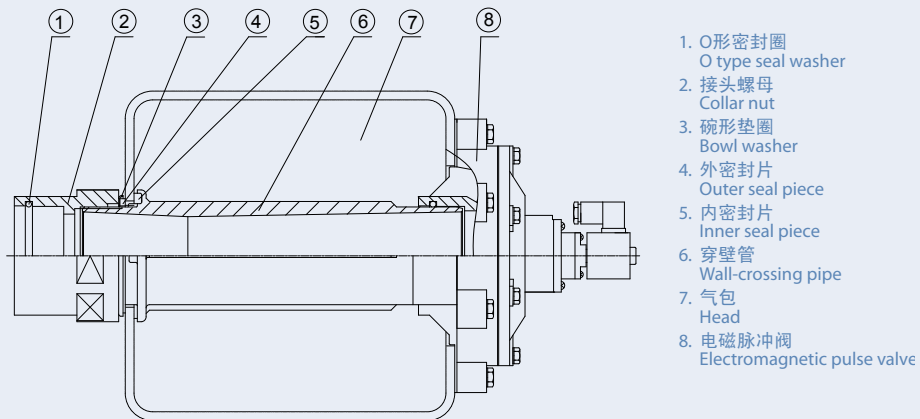
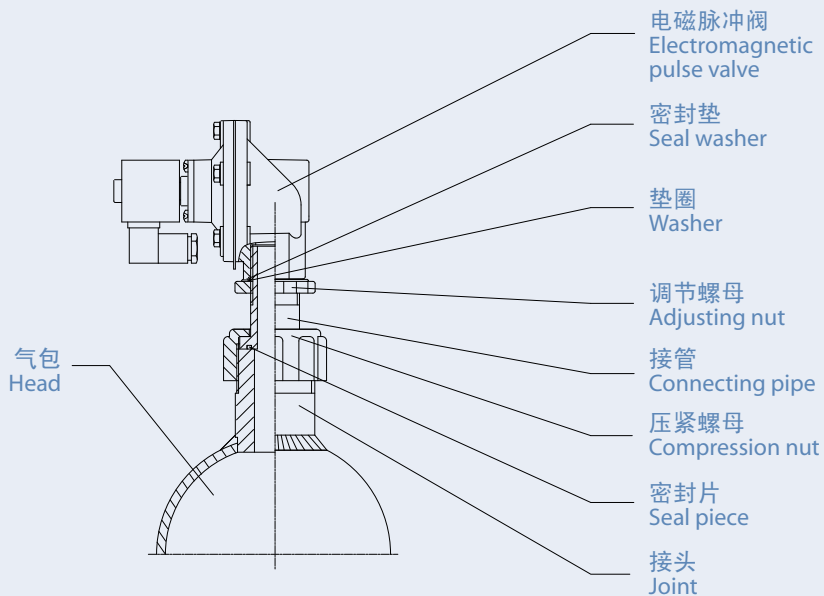

购买时请用户注意:

在订购时请用户注意FAP型穿壁连接器的型号规格、适用场合及组成零部件。
随着技术的发展, 本文内容可能会有所变动, 恕不另行通知。用户可向本公司查询。

Please pay attention to the following points when placing orders:

Please pay attention to the models, specifications, application and parts when placing orders for FAP wall connector.

We keep the right to revise the datum because of the technical development without any prior informing, please feel free to make an inquiry to our company.



更多产品

MORE PRODUCTS ▼



电磁脉冲阀
Electro-Magnetic Pulse Valve



滤袋
Filter Bag

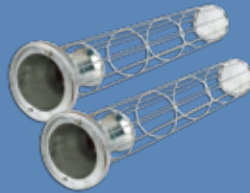

滤袋框架
Filter Bag Cage



清灰控制仪
Dust Control Device



电气控制柜
Electrical Control Cabinet

中国 CHINA

公司地址: 上海市虹三产业园古井路38号

Company Add: No.38, Hong san industrial area, 邮编Zip: 2000336

电话Tel: +86-19901761915

传真Fax: +86-21-54019615

E-mail: fionafu_aasf@163.com

AASF alibaba shop

professional

Shanghai AASF Technology Co., Ltd.

Leading Technology