

12' PULSING VALVE TECHNICAL DATA

AASF PVT LIMITED
Shanghai AASF Technology Co.,Ltd
上海焊思环保科技有限公司
134B-501, No.38 Gujing Rd, hong san
industrial area, shanghai, China, 200336.
电话: 86-21-54019615, 19901761915

RELATED 12' DIAPHRAGM KIT

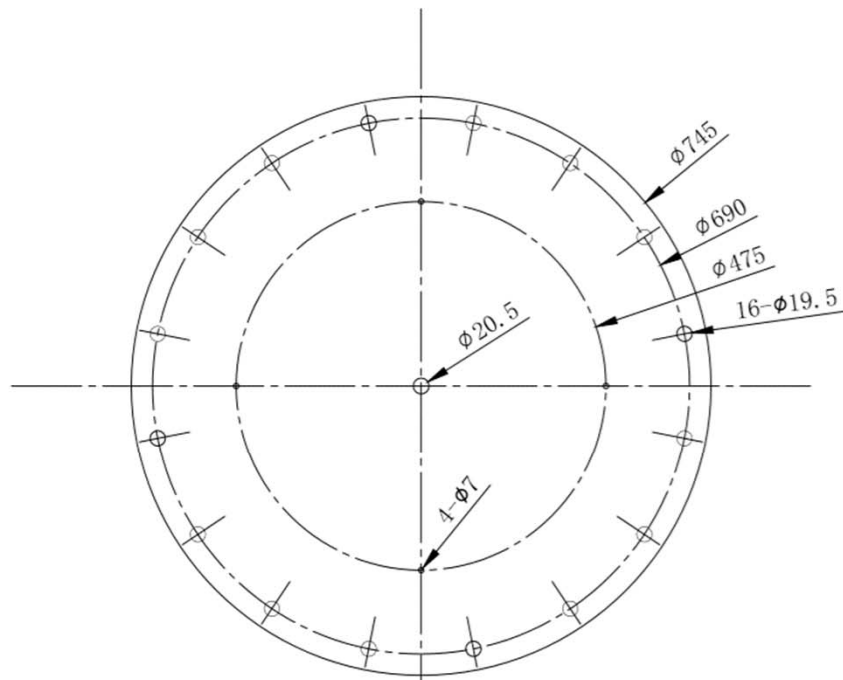

技术要求

1. Materials: Continental rubber
2. Thickness : 2 mm
3. Description: 12 inch Diaphragm

上海焊思环保科技有限公司			
Shanghai AASF Technology Co., Ltd.			
	比例	型号	
	数量 1	图号	AJ19042501
设计	K. Schufu	材料	
校对			
审核			



INSTALLATION DATAS

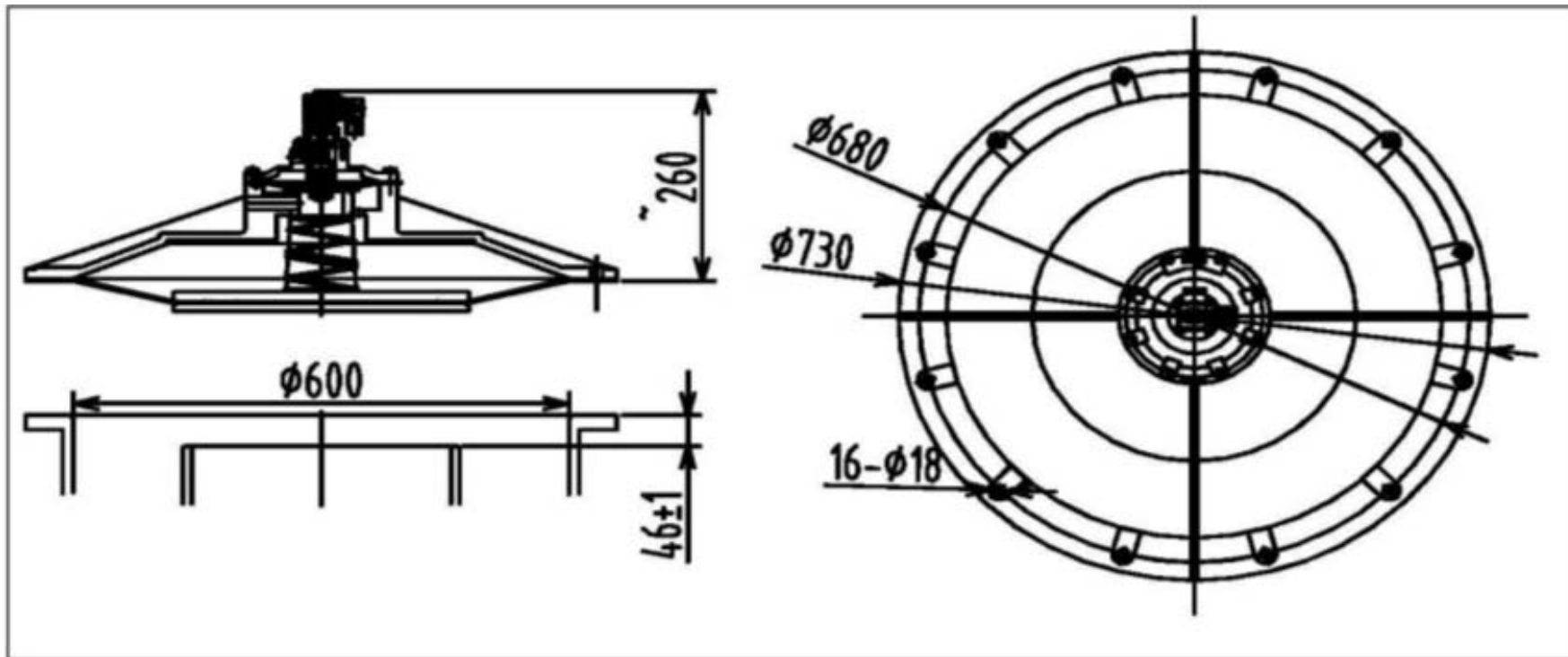

12" VALVE

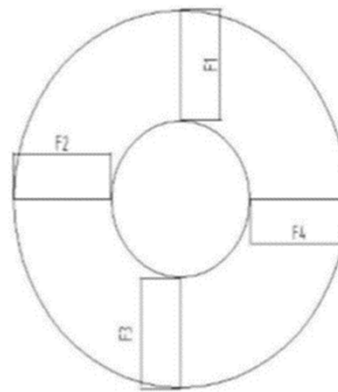
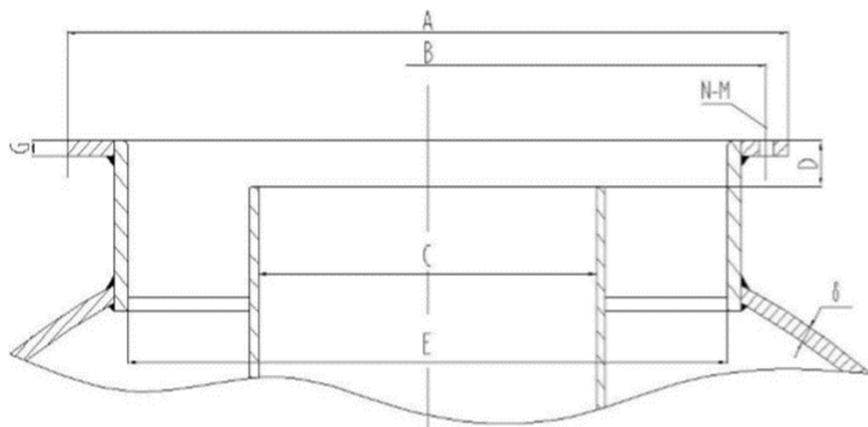
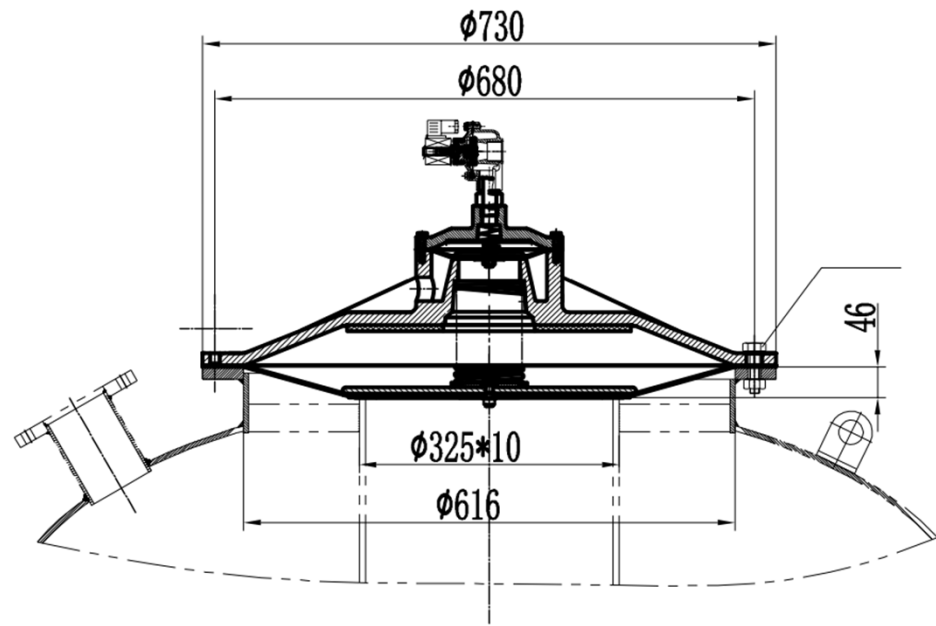
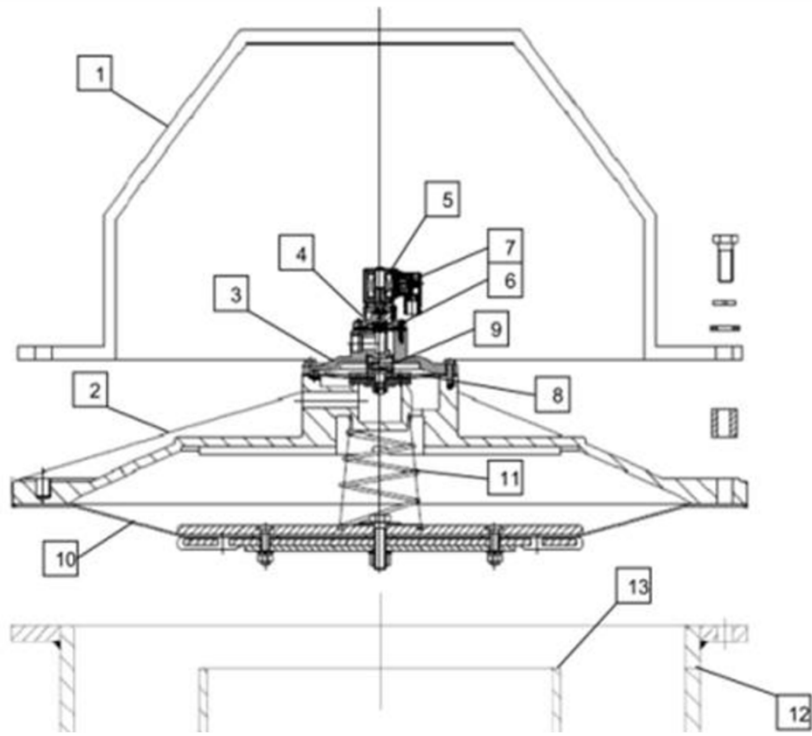

Name	air tank No.	air tank capacity (m3)	Installation dimension										
			A	B	Pipe diameter	C	D	E	F1	F2	F3	F4	
Pulse valve for 12-inch rotary bag dust collector (large valve)	A	1.5	735	680	Inner	310	45~46	600	135	140	142	138	
					Outer	325							
	B					Inner							
						Outer							
	C					Inner							
						Outer							
	D					Inner							
						Outer							
	E	1.5	735	690		Inner	310	43~47	600	137	135	139	140
						Outer	325						
	F					Inner							
						Outer							
	G	1.5	735	680		Inner	310	44~46	600	135	140	140	136
						Outer	325						
	H					Inner							

INSTALLATION INSTRUCTION

-----NOISE ENCLOSURE

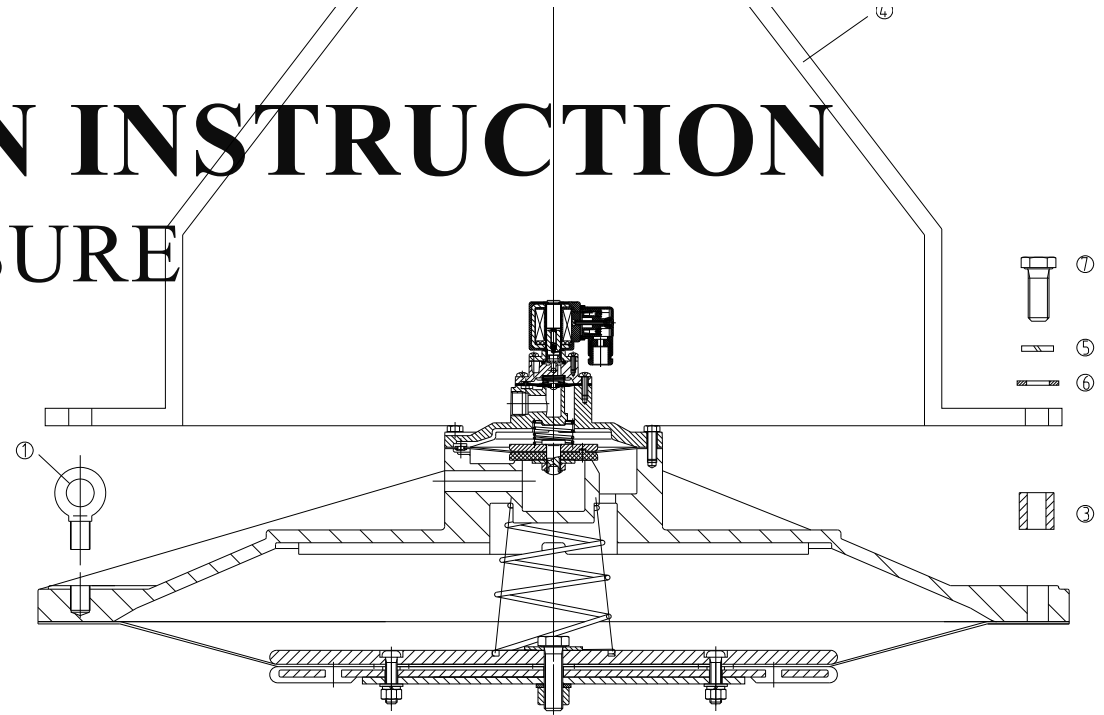

Lifting eye bolt × 2 ② 16-M16 ③ Aluminum tube × 4 ④ Noise enclosure

⑤ 4-M12S spring washer ⑥ 4-M12 flat washer ⑦ 4-M12 bolt

Installation of 12" Valve and Noise Enclosure:

- (1) Take out the parts and accessories of noise enclosure, valve deck, diaphragm components from the wooden box;
- (2) Screw 2pcs lifting eye bolts① into the screw holes of valve deck, and lift the valve deck, mount the diaphragm component,
- (3) spring and valve deck in sequence, then tighten bolt② in diagonal manner.
- (3) After meeting the requirements through debugging, screw out lifting eye bolts①, pad aluminum tube③,
- (4) mount noise enclosure④, place spring washer⑤&flat washer⑥, then tighten bolt⑦.